

Energy Division

Ground Fault Sensor Type 194-GF

Operation

All phase and neutral conductors of a single three-phase system should be passed through the sensor. Under the principle of zero-sequence phase current, normal phase and neutral current cancels out and only fault current is detected by the sensor. In some applications with a single ground strap, only the ground strap need be passed through the sensor.

Used in shipboard applications to comply with IEEE-45, the sensor secondary terminals can be open-circuit without damage to the sensor and without risk of creating hazardous voltages at the terminals.

The output permits display of fault currents up to 10 amps and an overload condition up to 1000 amps. An overload current of 500 amps can be tolerated indefinitely and 1000 amps will be tolerated long enough for circuit protection devices to operate.

Installation

Mounting of the sensor will follow normal procedure for a toroidal current transformer, except for the requirement to group all system conductors together before passing through the center opening. The output from the sensor is 0-1mADC into 50-ohms total load. Any analog indicator type can be scaled according to the sample scale shown.

0 0.3 0.5 1.0 1.5 2.0 3.0 5.0 10 1000 Amps, Ground Fault



0 0.06 0.14 0.35 .57 0.71 0.82 0.9 0.95 1.00 mADC, Sensor Output

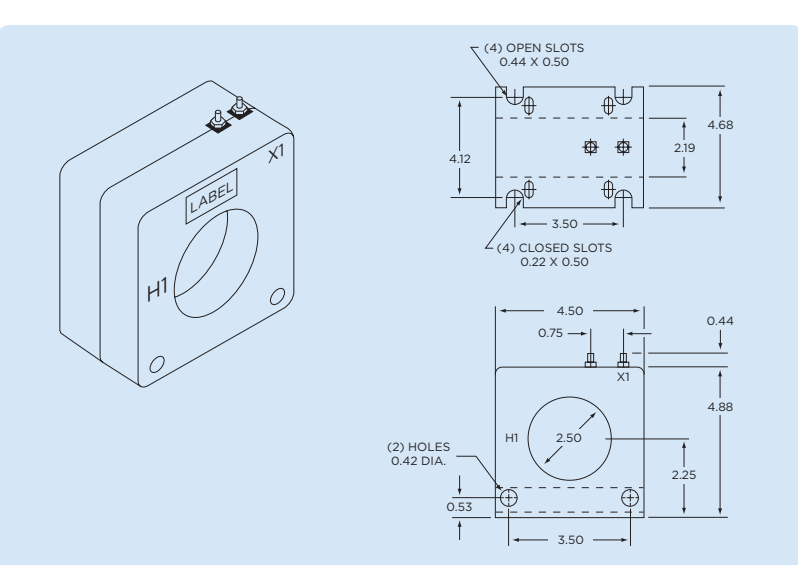

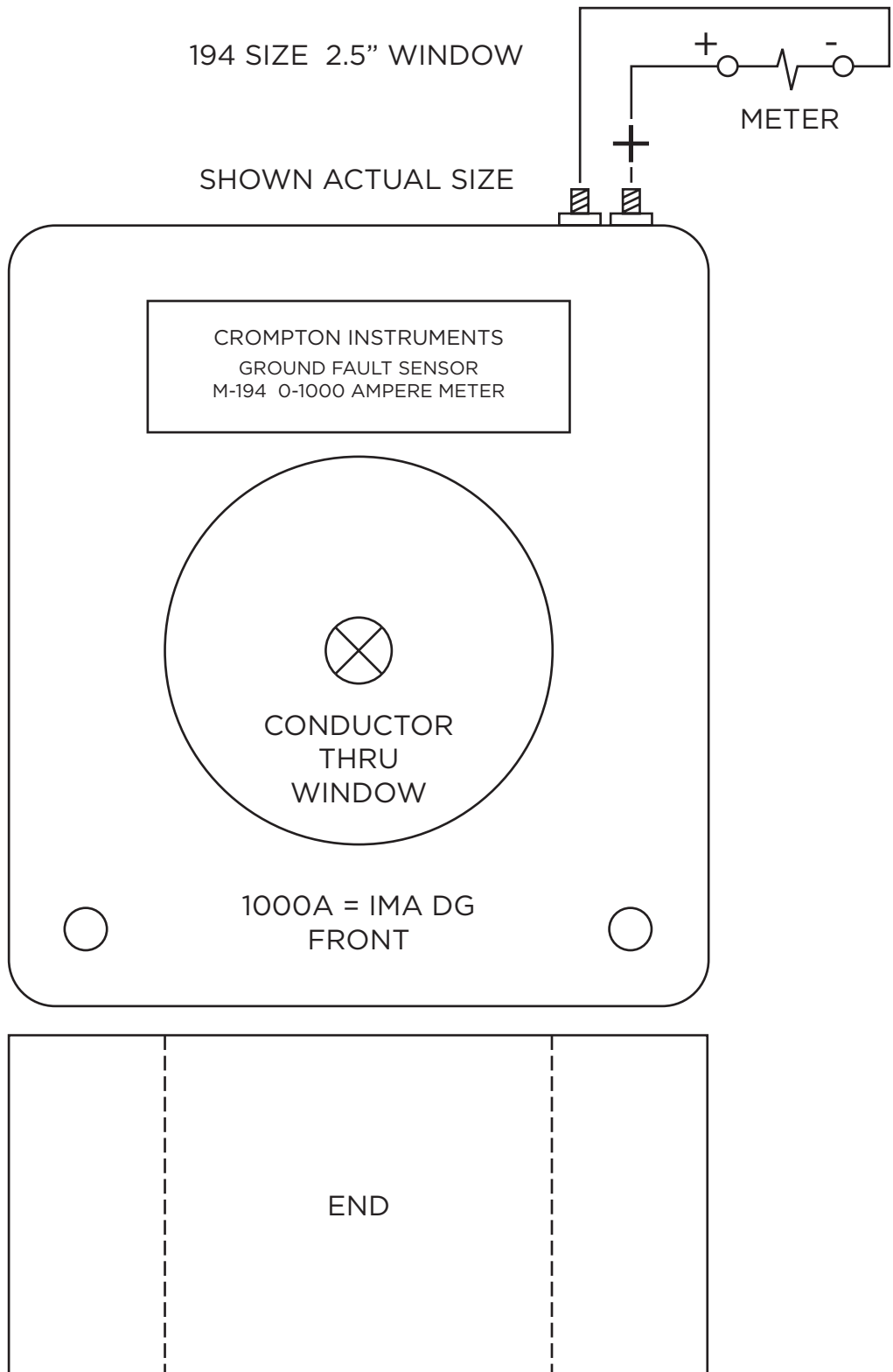

All of the above information, including drawings, illustrations and graphic designs, reflects our present understanding and is to the best of our knowledge and belief correct and reliable. Users, however, should independently evaluate the suitability of each product for the desired application. Under no circumstances does this constitute an assurance of any particular quality or performance. Such an assurance is only provided in the context of our product specifications or explicit contractual arrangements. Our liability for these products is set forth in our standard terms and conditions of sale. TE logo and Tyco Electronics are trademarks. CROMPTON is a trademark of Crompton Parkinson Ltd. and is used by Tyco Electronics under licence.

Energy Division - economical solutions for the electrical power industry: cable accessories, connectors & fittings, electrical equipment, instruments, lighting controls, insulators & insulation enhancement and surge arresters.

Tyco Electronics
 Crompton Instruments Facility
 1620 Cobb International Blvd, Suite 4,
 Kennesaw, Georgia, 30152 USA

Phone: 1-800-425-8903
 Fax: 1-800-423-7194

www.cromptonusa.com
 www.crompton-instruments.com



Tyco Electronics
 Our commitment. Your advantage.

Tyco Electronics CI-EPP-GFSENSOR194-US-07/07